

OEM Actuator 5: 120 V Standard

The OEM Actuator 5: 120 V Standard is a thermoelectric valve drive for opening and closing valves on heating circuit distributors of concealed floor heating and cooling systems. The main field of application is the energy-efficient individual room temperature control in the range of building management systems and home automation. The OEM Actuator 5: 120 V Standard is controlled by a 120 V room thermostat with two point output or pulse-width modulation.

The OEM-Actuator of the fifth generation has been developed especially for customer-specific usage in the OEM business. The modular design offers several possibilities for differentiations for tailor-made versions.



1.1 Features

- Modern OEM design
- Stroke variants 4.0 mm / 5.0 mm (other stroke variants on demand)
- Available in normally closed (NC) or normally open (NO)
- Power consumption 1 watt
- Complete compatibility to Valve-Adapter-System
- Simple snap-on installation
- 360° installation position
- Patented 100% protection against leaky valves
- First-Open function (NC type only, optional)
- Adaptation check on valve
- Alignment aid on the valve
- Compact size, small dimensions
- All around function indicator
- Noiseless and maintenance-free
- High functional safety and long expected service life
- Surge protection guarantee
- Certified by TÜV

1.2 Versions

In the basic version the OEM Actuator 5: 120 V Standard is delivered as a neutral version without logo, with fixed connecting cable, function indicator blue / gray, without valve adapter and laser marking. The following versions are available in the basic version.

Versions 120 V	Stroke	Actuating force	De-energised state	Closing and opening time	"First-Open" function	Scope of supply
A 10405-00N	4.0 mm	100 N	NC	approx. 3.5 min	yes	<ul style="list-style-type: none"> • OEM Actuator 5: 120 V Standard in single package • 1 meter connecting cable, grey, PVC NISPT 1 2 x AWG 18 • installation manual in 12 languages
A 10405-10N	4.0 mm	100 N	NC	approx. 3.5 min	no	
A 11405-10N	4.0 mm	100 N	NO	approx. 3.5 min	no	
A 10505-00N	5.0 mm	100 N	NC	approx. 4 min	yes	
A 10505-10N	5.0 mm	100 N	NC	approx. 4 min	no	
A 11505-10N	5.0 mm	100 N	NO	approx. 4 min	no	

Optionally, the following extensions and differentiations of the basic version are available:

Cable length	2 m, 3 m, 5 m, PVC NISPT 1 grey – 2 x AWG 18
Valve Adapter	Adapters are available for all standard valves and manifolds
Packaging	Packaging can be printed or produced individually according to your requirements
Imprint on casing	Laser imprint of your company logo and of an individual type designation
Colour of casing and cable	Homogenous colouring, colour function indicator and function cap, matching your product design or corporate design.
NRTL approval	Approval according to UL specification.
Further versions available on request.	

Accessories

- Protection Cap SK 1004

2 Functions

The actuator mechanism of the OEM-Actuator uses a PTC resistor-heated wax element and a compression spring. The wax element is heated by applying the operating voltage and moves the integrated ram. The force generated by the movement is transferred on the valve lifter and thus opens and closes the valve.

2.1 NC: Normally Closed (valve closed)

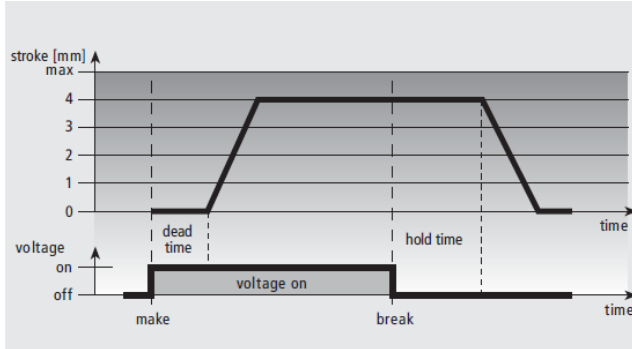

In case of the normally closed version, the valve is opened steadily by the ram motion upon switching on the operating voltage and after expiry of the dead time.

After the operating voltage is cut and after expiry of the hold time, the valve is closed evenly by the closing force of the compression spring. The closing force of the compression spring is matched to the closing force of commercially available valves and keeps the valve normally closed.

Fig.: Example for 4 mm stroke. Characteristic line for stroke 5 mm results analogous.

2.2 NO: Normally Open (valve opened)

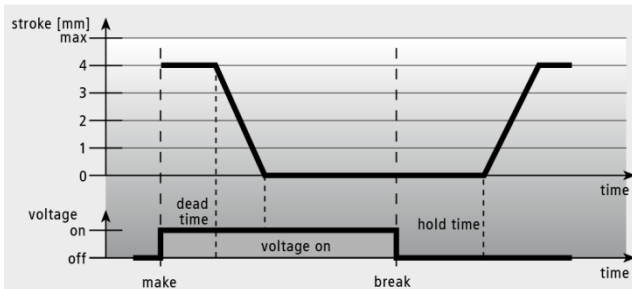

In case of the normally open version, the valve is closed evenly by the ram motion upon switching on the operating voltage and after expiry of the dead time.

After the operating voltage is cut and after expiry of the hold time, the valve is opened evenly by the closing force of the compression spring.

Fig.: Example for 4 mm stroke. Characteristic line for stroke 5 mm results analogous.

2.3 Function Display

The function display of the OEM-Actuator (all-around display) allows identifying the operating condition (valve open or closed) at a glance.

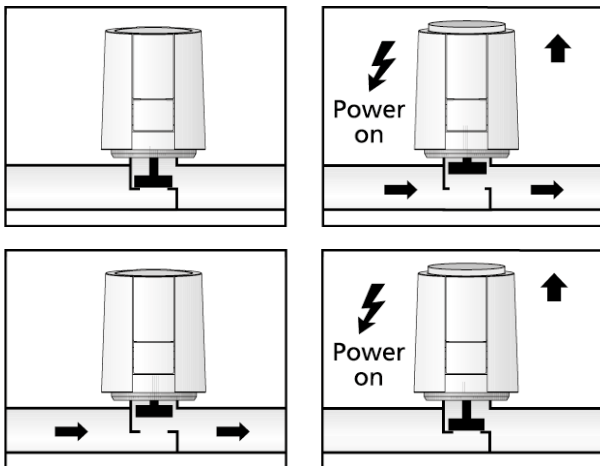

- In case of the **NC version**, an extended function display shows opening of the valve.
- In case of the **NO version**, an extended function display shows that the valve is closed.

2.4 First-Open Function (for NC only)

In its delivery condition, the OEM-Actuator is kept open when de-energised due to the First-Open function. This enables heating operation during the carcass construction phase even when the electric wiring is not yet complete. During the later electrical start-up, the First-Open function is unlocked by applying the operating voltage for more than 6 minutes. The OEM-Actuator will then be completely operable.

3 Technical Informations

Operating voltage		120 V AC, +15 %...-15 %, 50/60 Hz	1) measured with precision reference instrument LMG95 2) in dependence of the adapter even higher 3) in all installation positions
Max. inrush current		< 450 mA for max. 100 ms	
Operating power		1 W ¹⁾	
Stroke (actuator travel)		4.0 / 5.0 mm	
Actuating force		100 N +5 %	
Fluid temperature		0 to +100°C ²⁾	
Storage temperature		-25°C to +60°C	
Ambient temperature		0 to +60°C	
Type of protection		IP 54 ³⁾	
Protection class		II	
Certification		Approval according to UL 60730	
Housing	material	Polyamid	
	colour	grey (RAL 7035)	
Connecting cable	type	2 x AWG 18, PVC	
	colour	grey (RAL 7035)	
	length	1 m	
Weight with connecting cable (1 meter)		100 g	
Surge protection according to EN 60730-1		2 kV	

3.1 Dimensions

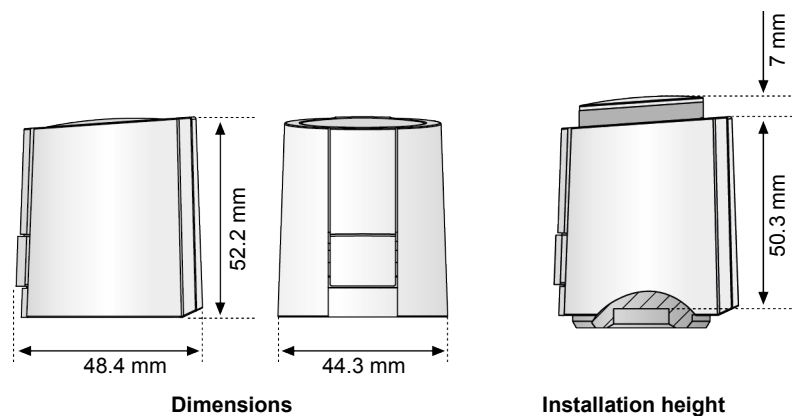

3.2 Certificate



The OEM Actuator 5 is certified by TÜV Süd.

4 Installation notes

4.1 Installation with Valve Adapter

The wide selection of valve adapters guarantees a perfect match of the OEM-Actuator to almost any valve bottom or manifold available on the market. Simply snap-on the OEM-Actuator to the manually pre-installed valve adapter.

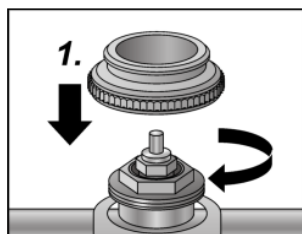

Screw the valve adapter manually on the valve.

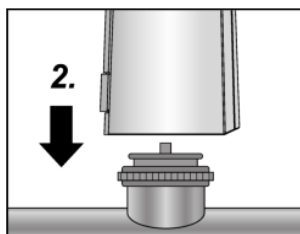

Place the OEM Actuator 5 vertically on the valve adapter.

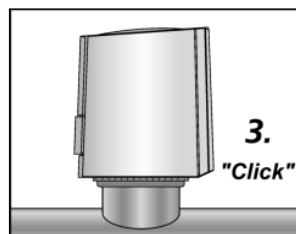

The OEM Actuator 5 snaps onto the valve adapter with a "Click" when pressed down vertically by hand.

4.2 Installation Positions

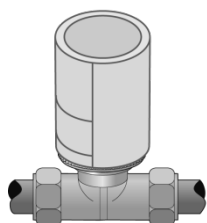

Vertical

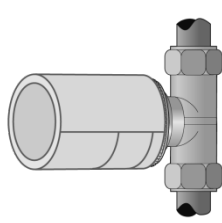

Horizontal

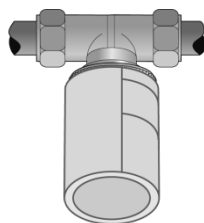

Upside Down

Preferred installation position of the OEM-Actuator is vertical or horizontal. An upside down position may reduce product life through special circumstances (e.g. contaminated water).

4.3 Electrical Installation

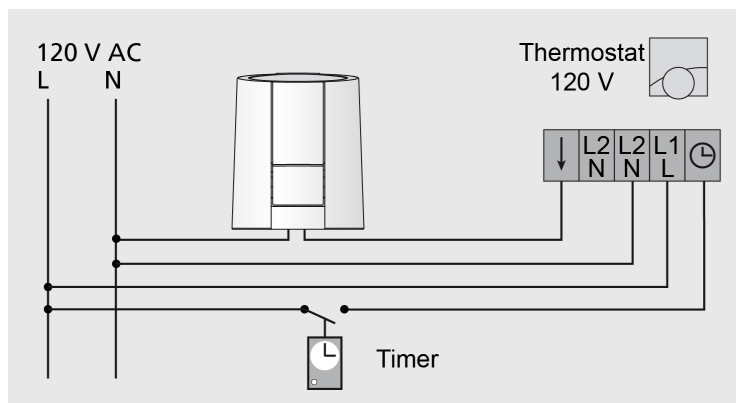

We recommend usage of the following lines for installing a 120 V system:

Wire cross section: AWG 16

Technical changes reserved. Reprint, in whole or in part, only with permission of Möhlenhoff GmbH.